

FB1100 Series INSTRUMENTS

HIGH-PERFORMANCE, LOW-COST INSTRUMENTS FOR BASIC WEIGHING APPLICATIONS

FAIRBANKS

FB1100

ACTUAL
DISPLAY
SIZE!

1100 lb

NET



CHARGE



Warehousing • Agriculture • Food Processing • Textile • Recycling • Manufacturing

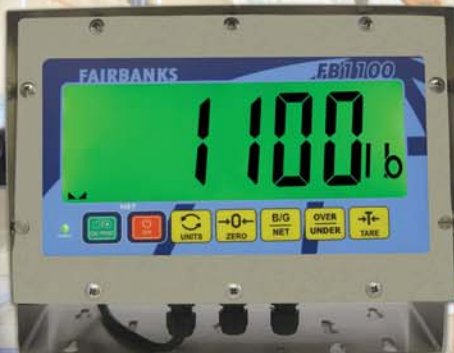

Stainless steel model



ABS model



VISIT OUR WORLD TODAY: WWW.FAIRBANKS.COM

FB1100 Series INSTRUMENTS



HIGH-PERFORMANCE, LOW-COST INSTRUMENTS FOR BASIC WEIGHING APPLICATIONS

USER-SELECTABLE BACKLIGHT!

Combine the FB1100 with floor and bench scales for exceptional weighing results!



COMMERCIALLY APPROVED!



Seven function keys provide quick access to commonly used features!

DISPLAY VISIBLE FROM 70 FEET!

SPECIAL FEATURES

- Designed to work with any manufacturer's analog bench scales, floor scales and weighing assemblies in a wide variety of basic weighing applications.
- Incredibly large 2" display is easy to see from 70 feet in indoor lighted (fluorescent) conditions and 100 feet in the dark.
- Standard output allows for simple connectivity to UPS® shipping software.
- Serial port enables printer, PC or remote display connectivity.
- Basic checkweighing feature with programmable audio alarm and/or visual reference.

SPECIFICATIONS

Display	2.0" high, 7-segment, 5½-digit LCD with user selectable green backlight
Enclosure	Black ABS plastic, NEMA 12 rated; Stainless steel, NEMA 4X rated
Pushbutton keys	On/Print, Off, Units, Zero, B/G Net, Over/Under, Tare
Units	lb, kg
Capacity	Selectable 0 to 199,999
Graduation size	0.00001 to 100
Load cells	Up to four 350Ω cells or eight 700Ω cells
Power requirements	115 VAC
Mounting	Desk/wall mount stand included on stainless models
Output	Bi-directional RS232
Accessories	Optional battery
Approvals	NTEP CC# 09-071, MC# AM-5745

ABS PLASTIC NEMA 12-RATED ENCLOSURE

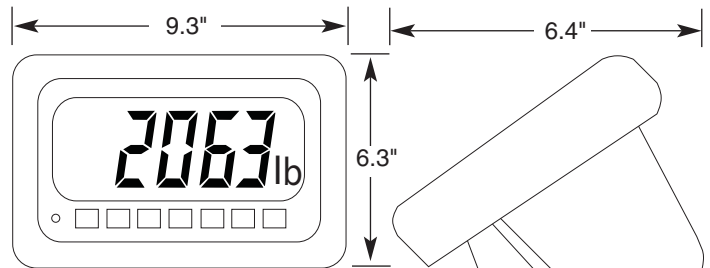

STAINLESS STEEL NEMA 4X-RATED ENCLOSURE

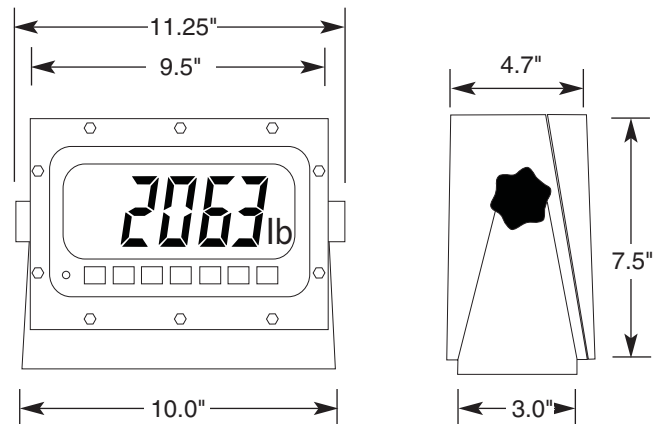

Call toll-free for the representative nearest you:

(800) 451-4107

Call between 8:00 a.m. – 5:00 p.m. Central Time

Corporate Offices: 821 Locust • Kansas City, MO 64106 • (816) 471-0231

www.Fairbanks.com



St. Johnsbury manufacturing facility registered in compliance with ISO 9001:2000.

