



Ranger™ Series

Compact High-Resolution Industrial Bench Scales



RD15LM,
RD35LM models



RD6RM model



RD3RM model



Ultra-Precise, Fast Industrial Bench Scales in Rugged Cast Aluminum Housings

The OHAUS Ranger™ line of high-resolution compact bench scales has been upgraded and expanded with new software and models for even better performance in demanding industrial applications. The Ranger High-Resolution line now combines a MFR loadcell with an enhanced microprocessor and updated filtering software for improved performance in the lab, on the production line, or in the field.

Every Ranger features a large, backlit LCD display with fast display of weighing results within 2 seconds, as well as a RS232 port for quick connectivity to printers and systems. For use in applications requiring additional filtering, the Ranger series now includes dynamic weighing software allowing weigh determination where vibration is an issue.

Every Ranger is designed with OHAUS' easy-to-use software interface, making operation intuitive with a consistent feel across all four Ranger lines: Ranger, Ranger High Resolution, Ranger Count and Ranger Count Plus. No matter the industrial need, there is a Ranger for that application!

Standard Features Include:

- High performance MFR loadcells for added precision, encased in a tough painted cast aluminum housing
- Wide range of platforms and capacities from 6lb to 70lb
- Weigh in lb, oz, kg or g units
- Large, backlit LCD display
- Dynamic weighing software included
- RS232 interface included, optional second RS232 available
- 1:300,000 default resolution, NTEP 1:30,000 legal-for-trade resolution
- Built-in AC with hardwired plug, factory-installed NiMH battery optional

Ranger™ Series High-Resolution Bench Scales

Specifications

Model	RD3RM	RD6RM	RD15LM	RD35LM
Default Capacity x Readability	6.61388 x 0.00002 lb 105.8228 x 0.0002 oz 3 x 0.00001 kg 3000 x 0.01 g	13.22770 x 0.00005 lb 211.6440 x 0.0005 oz 6 x 0.00002 kg 6000 x 0.02 g	33.0694 x 0.0001 lb 529.110 x 0.002 oz 15 x 0.00005 kg 15,000 x 0.05 g	77.1620 x 0.0002 lb 1234.592 x 0.002 oz 35 x 0.0001 kg 35,000 x 0.1 g
Capacity x Readability NTEP Certified	6 x 0.0002 lb 3 x 0.0001 kg	12 x 0.0005 lb 6 x 0.0002 kg	30 x 0.001 lb 15 x 0.0005 kg	60 x 0.002 lb 30 x 0.001 kg
Scale with NiMH Internal Battery	RD3RM/1	RD6RM/1	RD15LM/1	RD35LM/1
Scale with Second RS232	RD3RM/2	RD6RM/2	RD15LM/2	RD35LM/2
Scale with NiMH Battery and 2nd RS232	RD3RM/3	RD6RM/3	RD15LM/3	RD35LM/3

General Specifications

Platform Size (W x D)	6.5 x 6.5 in / 165 x 165 cm	7.9 x 9.5 in / 200 x 240 cm	9.5 x 13.8 in / 240 x 350 cm
Safe Overload Capacity	150% of capacity		
Construction	Stainless steel weighing pan / Painted cast-aluminum housing		
Protection	IP43		
Weighing Units / Modes	lb, oz, g, kg / Weighing, Dynamic Weighing, Gross / Net / Tare		
Display	0.63 inch / 16 mm digit height, backlit LCD		
Keyboard	Six button membrane switch		
Stabilization Time	< 2 seconds		
Auto Zero Tracking	0.5, 1, 2, 5, 10d, OFF		
Power	Internal AC adapter, rechargeable NiMH battery optional		
Calibration	External span, 20 - 100%		
Operating Temperature	50° F to 86° F / 10° C to 30° C		
Net (Shipping) Weight	12 lb / 5.1 kg (15 lb / 6.7 kg)	24 lb / 10.6 kg (29 lb / 12.8 kg)	
Scale Dimensions (W x D x H)	10.5 x 13.2 x 4 in / 26.5 x 33.5 x 10 cm	14.2 x 14.6 x 4.5 in / 36 x 37 x 11.5 cm	
Shipping Dimensions (W x D x H)	16.5 x 19 x 10 in / 42 x 48 x 25 cm	20 x 20.5 x 10.5 in / 52 x 53 x 27 cm	

Standard Features

RS232 bi-directional interface, backlit LCD display, auto-off timer, internal AC power supply, leveling feet, leveling bubble, loop for security device, 6-key membrane keypad, rugged cast aluminum housing, auto zero tracking, retain zero data during power off, user selectable graduation, user selectable averaging and level sensitivity, primary and secondary display units user selectable, automatic taring, configurable primary and secondary RS232 port settings with programmable output header, supervisor lockout capability.

Factory Options and Accessories

Internal NiMH rechargeable battery, 2nd RS232 port, anti-theft device, protective in use cover, RS232 cables.

Compliance

- **Electrical/Emissions:** CE listed, meets AS/NZS4251.1 Emission/AS/NZS4252.1 Immunity, FCC Class B Part 15 operation, Industry Canada Class A. cULus AC power pack. Compliant to Directive 2002/96/EC on waste electrical and electronic equipment (WEEE).
- **Legal-for-Trade:** NTEP Certified (certificate #07-026, Class II), OIML R76 Class III and EC Type Approval
- **Quality:** Ohaus quality management system registered to ISO 9001:2000

Outline Dimensions

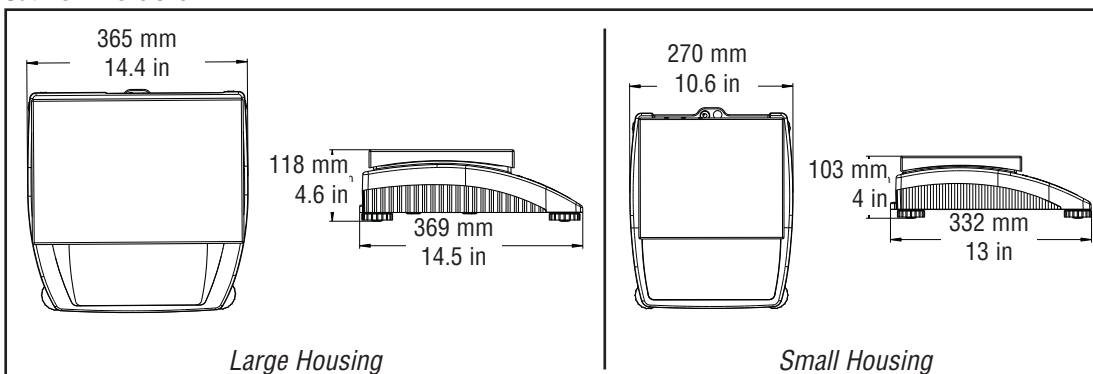

OHAUS CORPORATION

* 19A Chapin Road
P.O. Box 2033
Pine Brook, NJ 07058 USA

Tel: 800.672.7722
973.377.9000

Fax: 973.593.0359

www.ohaus.com

With offices throughout Europe,
Asia, and Latin America

* ISO 9001

Registered Quality Management System

